

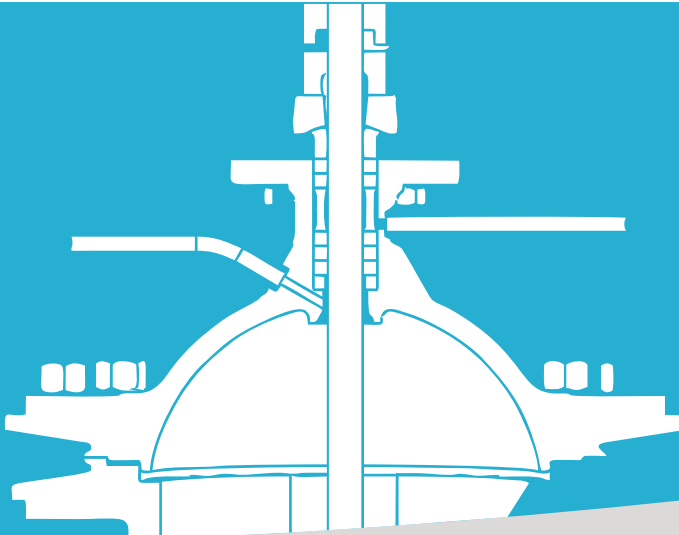

JASPAR Valves and Maintenance S.A.

Rue de la Cale Sèche, 30  
B-4684 OUPEYE

Tél. : +32-4/248 07 97  
info@jaspar.be



**Technical data sheet**  
**Pressure seal (cast and forget)**  
**valves**

**Globe, check-valves or gate valves**

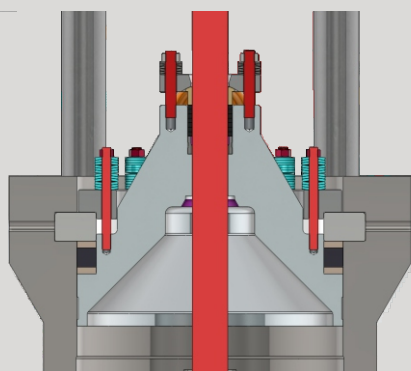

Design – construction  
ANSI B16.34 – ASME III – RCC-M

Valve classification  
ANSI 600 - 2500 lbs

End to End connection  
Flange, Socket or Butt welding

Body / Bonnet joint  
Pressure seal

Bore desing  
Full bore DN 50 – 600 mm

Seating  
Stellited grade 6

Motorisation  
Handwheel, pneumatic or electrical actuator

Applications

For high pressure ang high temperature valves(globe, check-valves, or gate valves).

In conventional thermal and nuclear power plants, high-pressure steam service.